

# First Measurement of Scintillation Photon Arrival Statistics Using a High-Granularity Solid-State Photosensor Enabling Time-Stamping of up to 20,480 Single Photons

J.R. Meijlink<sup>a</sup>, C. Veerappan<sup>a</sup>, S. Seifert<sup>a</sup>, D. Stoppa<sup>b</sup>, R.K. Henderson<sup>c</sup>, E. Charbon<sup>a</sup>, and D.R. Schaart<sup>a</sup>

<sup>a</sup>Delft University of Technology, Delft, The Netherlands

<sup>b</sup>Fondazione Bruno Kessler – IRST, Trento, Italy

<sup>c</sup>University of Edinburgh, Edinburgh, United Kingdom

## I. INTRODUCTION

Time-of-flight (TOF) information is essential to improve image quality in positron emission tomography (PET) [1]. In a PET system, the TOF information is derived from the scintillation light signal, as detected by the photon detector in use. The timing resolution of a PET system depends, among others, on the intrinsic properties of the detectors as well as the method by which their signals are processed and analyzed.

Compared to conventional analog silicon photo-multipliers (aSiPMs), digital SiPMs (dSiPMs) and arrays of individually accessible single-photon avalanche diodes (SPADs), make it possible to use more features of the measured scintillation pulse for estimating the true gamma arrival time ('time-stamping'), thus opening up new frontiers for obtaining a better overall timing resolution.

We propose a novel experimental method using a SPAD-TDC array that, for the first time, enables to simultaneously measure the spatial and time dependence of the photon arrival statistics in a scintillation detector with high resolution. By registering all available timing information contained in the scintillation pulse, this method makes it possible to study and develop new time-stamping techniques based on experimental data. In this paper, we present a proof-of-concept of the method including the first results obtained with a LYSO:Ce crystal.

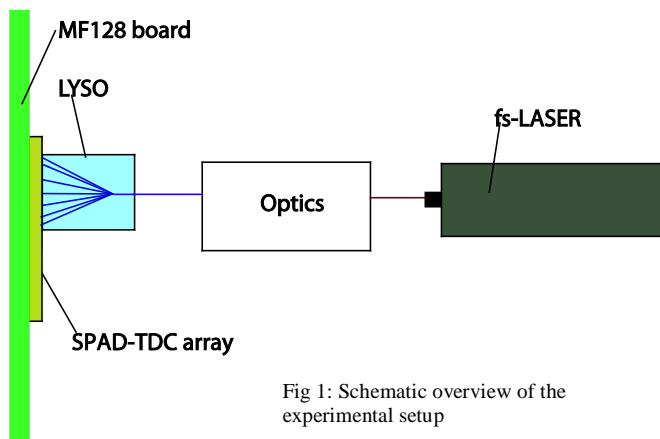

Fig 1: Schematic overview of the experimental setup

## II. MATERIALS AND METHODS

### a. PHOTON DETECTOR

The SPAD-TDC array consists of 160 x 128 micropixels on an area of 6.5 mm x 9 mm [2]. Every pixel consists of a SPAD and a time-to-digital converter (TDC). Thus each individual avalanche (triggered by a detected photon) can be time-stamped with a TDC resolution of 55 ps (1 LSB), the overall single photon timing resolution, or jitter, being equal to 140 ps [3].

Due to the large number of on-chip TDCs and other logic, the advantage of being able to time-stamp up to 20,480 individual scintillation photons goes at the expense of fill factor, resulting in a rather small photo-detection efficiency (PDE) of about 1%. Therefore a fs-UV-LASER is used to excite the crystal, allowing the generation of scintillation pulses of arbitrary intensity, so as to resemble those generated by 511 keV gamma quanta. A schematic representation of the measurement setup is given in Fig. 1. A LYSO:Ce crystal (3 mm x 3 mm x 5 mm; Crystal Photonics, Inc.) is placed on top of the SPAD-TDC array of a MegaFrame-128 (MF128) daughterboard using an optical coupling gel. A custom-made crystal holder fixes the position of the crystal on one quadrant of the sensitive area of the sensor. The MF128 daughterboard is connected to an FPGA motherboard (Enterpoint, Broaddown 4, dual Xilinx Virtex 4 LX80 processor) using the available Moel-Bryn sockets. The boards, shown in Fig. 2, are controlled by a PC via a USB-2 connection.

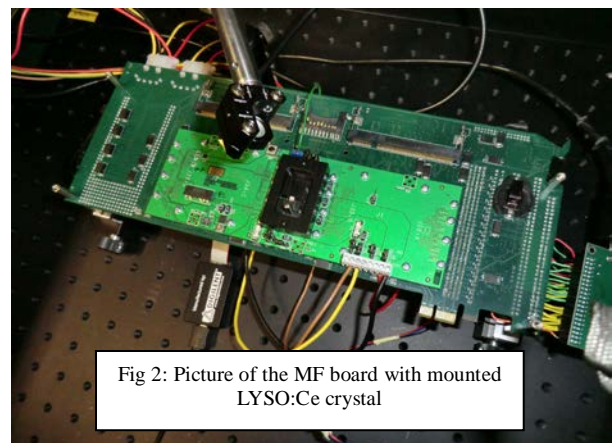

### b. LASER AND OPTICS

The LASER-system consists of a Nd:YVO<sub>4</sub> diode-pumped seed LASER (Coherent Verdi V10), a mode-locked Ti:Sapphire oscillator (Coherent Mira 900f, pulse length < 120 fs), a pulse-picker (APE Pulseselect) and a second/third harmonic generator (Photop TP-2000B). The oscillator is tunable between 680 – 1000 nm, which gives 340-500 nm and 230-330 nm using second and third harmonics, respectively. The pulse-picker can be used to reduce the pulse repetition rate from the original 76 MHz to frequencies as low as 15 kHz. The LASER-beam is redirected by mirrors into a dark box, in which the photon detector and crystal are placed.

### c. OPERATING MODE

The MF128-board is operating in time-correlated single-photon counting mode (TCSPC mode). In this mode of

operation, every TDC can run only once per frame (the frame rate being equal to 25 kHz). A fired SPAD generates a START for its corresponding TDC, while the clock signal from the pulse picker of the LASER generates a global STOP for all TDCs. The 10 bit output code of each TDC corresponds to the difference between these START and STOP signals. At the end of each frame, all TDC codes are shifted into a buffer (waiting to be read out) so that the TDCs can be used again in the next frame. The data acquisition system then moves the data from the buffer to the FPGA board (without interrupting the data generation), from where it is streamed to a PC via USB-2.

### III. RESULTS

#### a. SCINTILLATION PULSE SHAPE

The histogram of the excitation of the LYSO crystal is shown in Fig. 3. Here, the LASER excites the crystal with a wavelength of 250 nm at a pulse rate of 760 kHz. For this histogram, 8000 frames of data were collected from an area of 53 by 53 micropixels at a frame rate of 25 kHz. Pixels with a dark count rate of 1.5 kHz and higher are disregarded in the data analysis. Because of the limited TDC-range of 55 ns, only the first part of the scintillation curve is visible (the decay time constant of LYSO:Ce is 41 ns [5]).

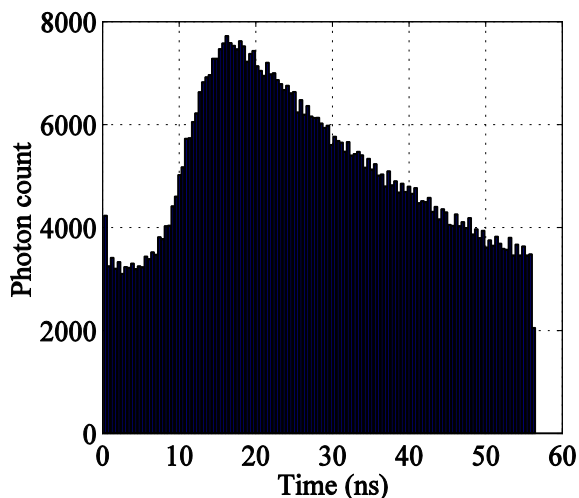

Fig 3: Measured time response histogram

#### b. PHOTON COUNTING STATISTICS

Using the same dataset as above, the time-stamps of every 1st, 2nd, 3rd, etc., arriving photon in a frame is analyzed. Fig. 4 shows a mean timestamp (averaged over 8000 frames) for every  $n$ th arriving photon ( $0 < n < 90$ ). Fig. 5 shows the standard deviation on this mean arriving time.

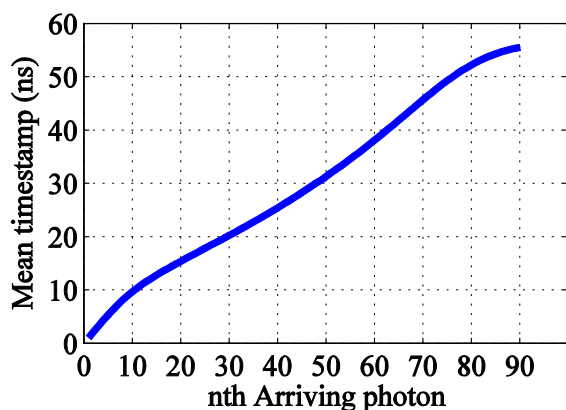

Fig 4: Mean timestamp of every  $n$ th arriving photon

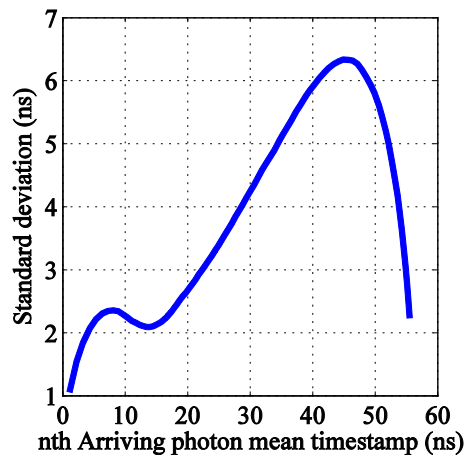

Fig 5: Standard deviation of every  $n$ th arriving photon

### IV. DISCUSSION AND CONCLUSIONS

In this work we discuss a novel method capable of measuring time and spatial information of all detected scintillation photons. Currently, the overall time resolution is still very much limited by a sub-optimal setup, while the intrinsic specifications of the MF-board ensure to achieve a significantly better performance. This is e.g. evident from the significant time blurring of the recorded scintillation pulse shape in Fig. 3. The main cause for this is believed to be the clock distribution system. In addition, the STOP signal propagation through the device is affected by systematic delay skews in the order of 1 ns that are not yet compensated for. Finally, the time jitter introduced by the clock synthesizer and the LASER synchronizers is still large and will be improved significantly. Corrective actions and experiments to overcome these issues are ongoing.

Moreover, operating the LASER at different settings will have the effect of increasing the signal-to-noise ratio (SNR) that is currently deemed much too low. Experiments with a significantly higher SNR are in progress.

Despite the current limitations of our prototype setup, our first results indicate the potential of this setup in delivering insight into scintillation photon arrival statistics and in verifying results predicted from order statistics on the probability distributions of scintillation photon counting. Fig. 5, for example, shows interesting features of the competition between noise photons (dark counts) and scintillation photons, which reflects in the standard deviation in the arrival time (see for example [4]). In upcoming experiments, we will improve the time-stamping precision by optical LASER synchronization. It will then be possible to derive estimators for (conditional) probability density distributions for every  $n$ -th scintillation photon.

### V. REFERENCES

- [1] M. Conti, "Focus on time-of-flight PET: the benefits of improved time resolution", *European Journal of Nuclear Medicine and Molecular Imaging*, Issn: 1619-7070, pp. 1-11, 2011
- [2] <http://www.megaframe.eu/>
- [3] Veerappan, C.; Richardson, J.; Walker, R.; Day-Uey Li; Fishburn, M.W.; Maruyama, Y.; Stoppa, D.; Borghetti, F.; Gersbach, M.; Henderson, R.K.; Charbon, E., "A 160x128 single-photon image sensor with on-pixel 55ps 10b time-to-digital converter," *Solid-State Circuits Conf. Digest of Technical Papers (ISSCC), 2011 IEEE International*, pp.312-314, 20-24 Feb. 2011
- [4] Fishburn, M.W.; Charbon, E.; , "System Tradeoffs in Gamma-Ray Detection Utilizing SPAD Arrays and Scintillators," *Nuclear Science, IEEE Transactions on* , vol.57, no.5, pp.2549-2557, Oct. 2010
- [5] Pidol, L.; Kahn-Harari, A.; Viana, B.; Virey, E.; Ferrand, B.; Dorenbos, P.; de Haas, J.T.M.; van Eijk, C.W.E.; , "High efficiency of lutetium silicate scintillators, Ce-doped LPS, and LYSO crystals," *Nuclear Science, IEEE Transactions on* , vol.51, no.3, pp. 1084- 1087, June 2004